

COMPOSANTS A BRIDES KF

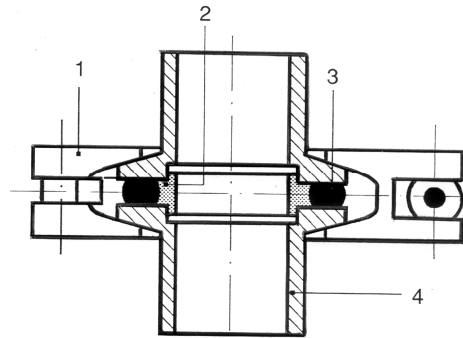

Descriptif :

Ce type de raccordement est composé de plusieurs éléments en acier Inox : (voir ci-dessus)

- 1 collier de serrage : **1**
- 1 anneau de centrage : **2**
- 1 joint : **3**
- Embouts : **4**

Principe de fonctionnement :

Chaque embout de tubulure se raccorde par l'intermédiaire d'un anneau de centrage portant le joint d'étanchéité. L'assemblage est maintenu par le collier de serrage qui agit sur la partie conque des embouts.

Performances :

- Etanchéité de haute qualité.
- Faible taux de dégazage.
- Pression : vide allant jusqu'à 10^{-7} mbar
- Serrage de l'ensemble sans outils particuliers
- Ø Couramment utilisés : de 10 à 50 mm.

Qualité :

Ces éléments à petites brides sont conformes à la norme "Pneurop" 6601/1981 et DIN 28403.
Etat de propreté : tous les éléments sont garantis en propreté et conditionnés dans des emballages plastiques.

Domaines d'utilisation :

- Technologie du vide.
- Industrie chimique.
- Nucléaire.

COMPOSANTS A BRIDES KF

Collier de serrage VKFCL

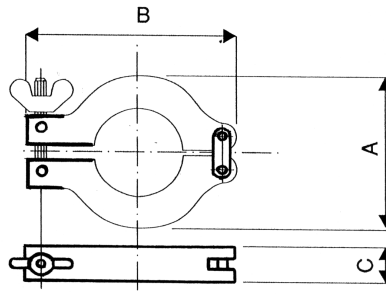

Ø nominal	A	B	C	Inox	Aluminium
DN 10-16-5/8"	45	62	16	VKFCL16I	VKFCL16A
DN 20-25-1"	55	73	16	VKFCL25I	VKFCL25A
DN 32-40-1" 1/2	70	90	16	VKFCL40I	VKFCL40A
DN 50-2"	95	123	25	VKFCL50I	VKFCL50A

Obturbateur simple VKFOS

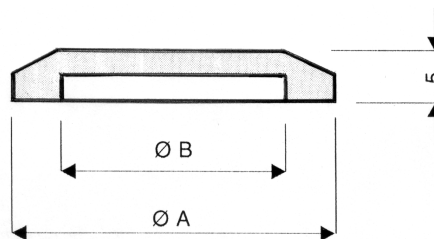

Ø nominal	A	B	Inox 316L	Inox 304	Aluminium
DN 16	30	17.2	VKFOS16IL	VKFOS16I	VKFOS16A
DN 25	40	26.2	VKFOS25IL	VKFOS25I	VKFOS25A
DN 40	55	41.2	VKFOS40IL	VKFOS40I	VKFOS40A
DN 50	75	52.2	VKFOS50IL	VKFOS50I	VKFOS50A

Obturbateur double VKFOD

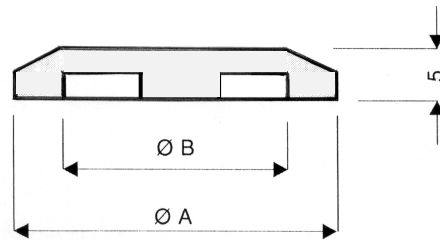

Ø nominal	A	B	Inox 316L	Aluminium
DN 10/16	30	17.2	VKFOD10IL16	VKFOD10A16
DN 20/25	40	26.2	VKFOD20IL25	VKFOD20A25
DN 32/40	55	41.2	VKFOD32IL40	VKFOS32A40

Anneau de centrage intérieur avec joint VKFA

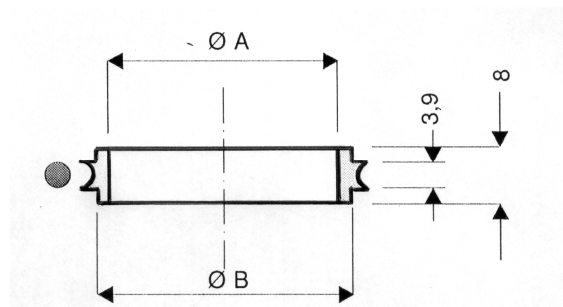

Ø nominal	A	B	Inox 316L/FKM	Inox 316L/EPDM	Inox 316L/NBR
DN 10	10	12	VKFA10ILV	VKFA10ILE	VKFA10ILN
DN 16	16	17	VKFA16ILV	VKFA16ILE	VKFA16ILN
DN 20	21	22	VKFA20ILV	VKFA20ILE	VKFA20ILN
DN 25	25	26	VKFA25ILV	VKFA25ILE	VKFA25ILN
DN 32	32	34	VKFA32ILV	VKFA32ILE	VKFA32ILN
DN 40	40	41	VKFA40ILV	VKFA40ILE	VKFA40ILN
DN 50	50	52	VKFA50ILV	VKFA50ILE	VKFA50ILN
Ø nominal	A	B	Inox 304/FKM	Inox 304/EPDM	Inox 304/NBR
DN 16	16	17	VKFA16IV	VKFA16IE	VKFA16IN
DN 25	25	26	VKFA25IV	VKFA25IE	VKFA25IN
DN 40	40	41	VKFA40IV	VKFA40IE	VKFA40IN
DN 50	50	52	VKFA50IV	VKFA50IE	VKFA50IN
Ø nominal	A	B	Aluminium/FKM	Aluminium/EPDM	Aluminium/NBR
DN 16	16	17	VKFA16AV	VKFA16AE	VKFA16AN
DN 20	21	22	VKFA20AV	VKFA20AE	VKFA20AN
DN 40	40	41	VKFA40AV	VKFA40AE	VKFA40AN
DN 50	50	52	VKFA50AV	VKFA50AE	VKFA50AN

Anneau de centrage de réduction avec joint

VKFAR

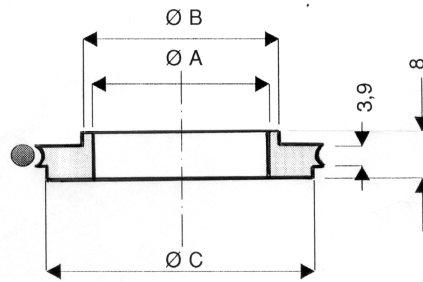

Ø nominal	A	B	C	Inox 316L/FKM	Inox 316L/EPDM	Inox 316L/NBR
DN 16-10	10	12	17	VKFAR16ILV10	VKFAR16ILE10	VKFAR16ILN10
DN 25-20	21	22	26	VKFAR25ILV20	VKFAR25ILE20	VKFAR25ILN20
DN 40-32	32	34	41	VKFAR40ILV32	VKFAR40ILE32	VKFAR40ILN32
Ø nominal	A	B	C	Inox 304/FKM	Inox 304/EPDM	Inox 304/NBR
DN 16-10	10	12	17	VKFAR16IV10	VKFAR16IE10	VKFAR16IN10
DN 25-20	21	22	26	VKFAR25IV20	VKFAR25IE20	VKFAR25IN20
DN 40-32	32	34	41	VKFAR40IV32	VKFAR40IE32	VKFAR40IN32
Ø nominal	A	B	C	Aluminium/FKM	Aluminium/EPDM	Aluminium/NBR
DN 16-10	10	12	17	VKFAR16AV10	VKFAR16AE10	VKFAR16AN10
DN 25-20	21	22	26	VKFAR25AV20	VKFAR25AE20	VKFAR25AN20
DN 40-32	32	34	41	VKFAR40AV32	VKFAR40AE32	VKFAR40AN32

Anneau de centrage extérieur avec joint

VKFAE

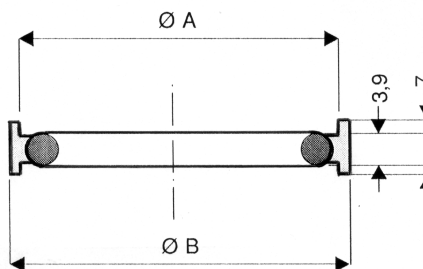

Ø nominal	A	B	Inox 316L/FKM	Inox 316L/EDPM	Inox 316L/NBR
DN 10-16	30	32	VKFAE16ILV	VKFAE16ILE	VKFAE16ILV
DN 20-25	40	42	VKFAE25ILV	VKFAE25ILE	VKFAE25ILV
DN 32-40	55	57	VKFAE40ILV	VKFAE40ILE	VKFAE40ILV
DN 50	76	78	VKFAE50ILV	VKFAE50ILE	VKFAE50ILV
Ø nominal	A	B	Aluminium/FKM	Aluminium/EDPM	Aluminium/NBR
DN 10-16	30	32	VKFAE16AV	VKFAE16AE	VKFAE16AV
DN 20-25	40	42	VKFAE25AV	VKFAE25AE	VKFAE25AV
DN 32-40	55	57	VKFAE40AV	VKFAE40AE	VKFAE40AV
DN 50	76	78	VKFAE50AV	VKFAE50AE	VKFAE50AV

Autre matière sur demande

Anneau de centrage intérieur avec joint + bague de renfort aluminium VKFA

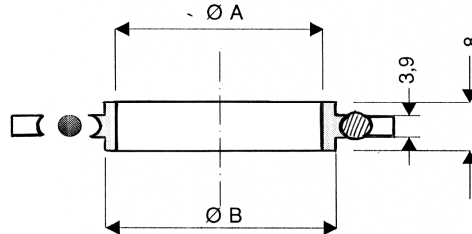

Ø nominal	A	B	Inox 316L/FKM/Alu	Inox 316L/EPDM/Alu	Inox 316L/NBR/Alu
DN 10	10	12	VKFA10ILVA	VKFA10ILEA	VKFA10ILNA
DN 16	16	17	VKFA16ILVA	VKFA16ILEA	VKFA16ILNA
DN 20	21	22	VKFA20ILVA	VKFA20ILEA	VKFA20ILNA
DN 25	25	26	VKFA25ILVA	VKFA25ILEA	VKFA25ILNA
DN 32	32	34	VKFA32ILVA	VKFA32ILEA	VKFA32ILNA
DN 40	40	41	VKFA40ILVA	VKFA40ILEA	VKFA40ILNA
DN 50	50	52	VKFA50ILVA	VKFA50ILEA	VKFA50ILNA
Ø nominal	A	B	Inox 304/FKM/Alu	Inox 304/EPDM/Alu	Inox 304/NBR/Alu
DN 16	16	17	VKFA16IVA	VKFA16IEA	VKFA16INA
DN 25	25	26	VKFA25IVA	VKFA25IEA	VKFA25INA
DN 40	40	41	VKFA40IVA	VKFA40IEA	VKFA40INA
DN 50	50	52	VKFA50IVA	VKFA50IEA	VKFA50INA

Anneau de centrage intérieur + filtre VKFAF

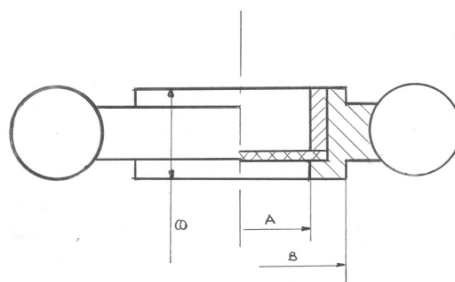

Ø nominal	A	B	FKM	EPDM	NBR
DN 16	13	17	VKFAF16V	VKFAF16E	VKFAF16 N
DN 25	22	26	VKFAF25V	VKFAF25E	VKFAF25 N
DN 40	36	41	VKFAF40V	VKFAF40E	VKFAF40 N
DN 50	48	52	VKFAF50V	VKFAF50E	VKFAF50 N

Anneau de centrage extérieur tout alu VKFAA

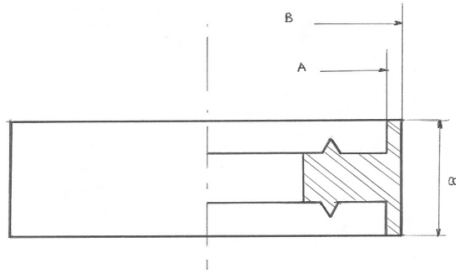

Ø nominal	A	B	Référence
DN 10/16	30	32	VKFAA10A16
DN 20/25	40	42	VKFAA20A25
DN 32/40	55	57	VKFAA32A40
DN 50	76	78	VKFAA50A

Joint VKFJ

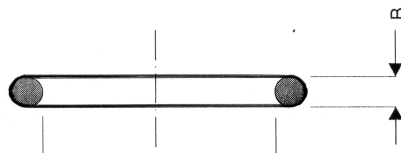

Ø nominal	A	B	FKM	EPDM	NBR
DN 10	15	5	VKFJ10V	VKFJ10E	VKFJ10N
DN 16	18	5	VKFJ16V	VKFJ16E	VKFJ16N
DN 20	25	5	VKFJ20V	VKFJ20E	VKFJ20N
DN 25	28	5	VKFJ25V	VKFJ25E	VKFJ25N
DN 32	40.6	5.3	VKFJ32V	VKFJ32E	VKFJ32N
DN 40	40.6	5.3	VKFJ40V	VKFJ40E	VKFJ40N
DN 50	53.3	5.3	VKFJ50V	VKFJ50E	VKFJ50N

Embout lisse court

VKFEC

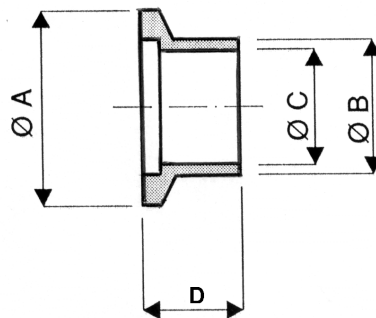

\varnothing nominal	A	B	C	D	Inox 316L
DN 10	30	6	4	20	VKFEC10IL6M
DN 10	30	6.35	4.57	20	VKFEC10IL4I
DN 10	30	12.7	10.92	20	VKFEC10IL8I
DN 10	30	14	10	20	VKFEC10IL14M
DN 10	30	16	12	20	VKFEC10IL16M
DN 16	30	10	8	20	VKFEC16IL10M
DN 16	30	13.7	9.80	20	VKFEC16IL4S
DN 16	30	14	10	20	VKFEC16IL14M
DN 16	30	17.2	14	20	VKFEC16IL6S
DN 16	30	18	16	20	VKFEC16IL18M
DN 16	30	19.05	17.3	20	VKFEC16IL12I
DN 16	30	20	16	20	VKFEC16IL20M
DN 16	30	21.3	18.10	20	VKFEC16IL8S
DN 20	40	21.3	18.10	20	VKFEC20IL8S
DN 20	40	24	20	20	VKFEC20IL24M
DN 20	40	25.4	22.1	20	VKFEC20IL16I
DN 20	40	26.9	23.7	20	VKFEC20IL12S
DN 25	40	25.4	22.10	20	VKFEC25IL16I
DN 25	40	26.9	23.7	20	VKFEC25IL12S
DN 25	40	28	25	20	VKFEC25IL28M
DN 25	40	33.7	30.5	20	VKFEC25IL16S
DN 32	55	33.7	30.5	20	VKFEC32IL16S
DN 32	55	38	32	20	VKFEC32IL38M
DN 32	55	38,1	35	20	VKFEC32IL24I
DN 32	55	42,4	39,2	20	VKFEC32IL20S
DN 40	55	33.7	30.5	20	VKFEC40IL16S
DN 40	55	38.1	35	20	VKFEC40IL24I
DN 40	55	42.4	39.2	20	VKFEC40IL20S
DN 40	55	44	40	20	VKFEC40IL44M
DN 40	55	48.3	45	20	VKFEC40IL24S
DN 50	75	48.3	45	20	VKFEC50IL24S
DN 50	75	50.8	47.5	20	VKFEC50IL32I
DN 50	75	54	50	20	VKFEC50IL54M
DN 50	75	57	50	20	VKFEC50IL57M
DN 50	75	60.3	57.1	20	VKFEC50IL32S
DN 50	75	63.5	60	20	VKFEC50IL36I

Embouts en inox 304 sur demande

Autres matières et autres cotes sur demande

Embout lisse long

VKFEL

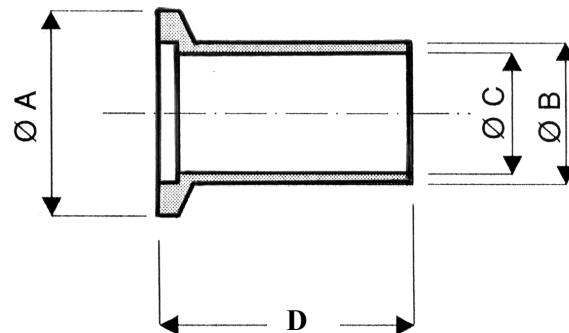

\varnothing nominal	A	B	C	D	Inox 316L
DN 10	30	6	4	40	VKFEL10IL6M
DN 10	30	6.35	4.57	40	VKFEL10IL4I
DN 10	30	12.7	10.92	40	VKFEL10IL8I
DN 10	30	14	10	40	VKFEL10IL14M
DN 10	30	16	12	40	VKFEL10IL16M
DN 16	30	10	8	40	VKFEL16IL10M
DN 16	30	13.7	9.80	40	VKFEL16IL4S
DN 16	30	14	10	40	VKFEL16IL14M
DN 16	30	17.2	14	40	VKFEL16IL6S
DN 16	30	18	16	40	VKFEL16IL18M
DN 16	30	19.05	17.3	40	VKFEL16IL12I
DN 16	30	20	16	40	VKFEL16IL20M
DN 16	30	21.3	18.10	40	VKFEL16IL8S
DN 20	40	21.3	18.10	40	VKFEL20IL8S
DN 20	40	24	20	40	VKFEL20IL24M
DN 20	40	25.4	22.1	40	VKFEL20IL16I
DN 20	40	26.9	23.7	40	VKFEL20IL12S
DN 25	40	25.4	22.10	40	VKFEL25IL16I
DN 25	40	26.9	23.7	40	VKFEL25IL12S
DN 25	40	28	25	40	VKFEL25IL28M
DN 25	40	33.7	30.5	40	VKFEL25IL16S
DN 32	55	33.7	30.5	40	VKFEL32IL16S
DN 32	55	38	32	40	VKFEL32IL38M
DN 32	55	38,1	35	40	VKFEL32IL24I
DN 32	55	42,4	39,2	40	VKFEI32IL20S
DN 40	55	33.7	30.5	40	VKFEL40IL16S
DN 40	55	38.1	35	40	VKFEL40IL24I
DN 40	55	42.4	39.2	40	VKFEL40IL20S
DN 40	55	44	40	40	VKFEL40IL44M
DN 40	55	48.3	45	40	VKFEL40IL24S
DN 50	75	48.3	45	40	VKFEL50IL24S
DN 50	75	50.8	47.5	40	VKFEL50IL32I
DN 50	75	54	50	40	VKFEL50IL54M
DN 50	75	57	50	40	VKFEL50IL57M
DN 50	75	60.3	57.1	40	VKFEL50IL32S
DN 50	75	63.5	60	40	VKFEL50IL36I

Embouts en inox 304 sur demande

Autres matières sur demande

Embout intermédiaire court VKFEIC

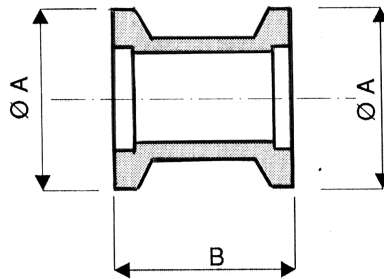

Ø nominal	A	B	Inox 316L
DN 16	30	40	VKFEIC16IL
DN 25	40	40	VKFEIC25IL
DN 40	55	40	VKFEIC40IL
DN 50	75	40	VKFEIC50IL

Embout intermédiaire long VKFEIL

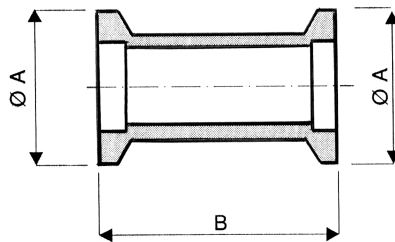

Ø nominal	A	B	Inox 316L
DN 16	30	100	VKFEIL16IL
DN 25	40	100	VKFEIL25IL
DN 40	55	100	VKFEIL40IL
DN 50	75	100	VKFEIL50IL

Embout de réduction droit

VKFERD

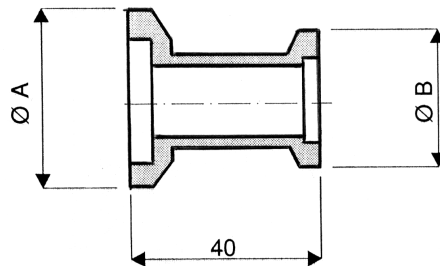

Ø nominal	A	B	Inox 316L
DN 25-10	40	30	VKFERD25IL10
DN 25-16	40	30	VKFERD25IL16
DN 40-16	55	30	VKFERD40IL16
DN 40-25	55	40	VKFERD40IL25
DN 50-25	75	40	VKFERD50IL25
DN 50-40	75	55	VKFERD50IL40

Embout de réduction conique

VKFERC

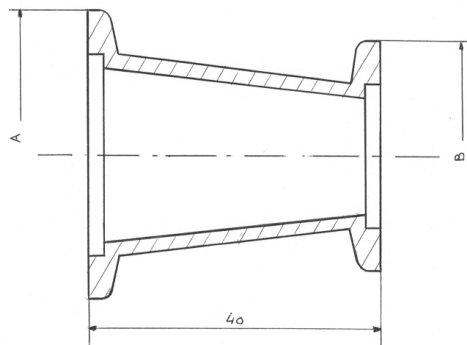

Ø nominal	A	B	Inox 304	Inox 316L
DN 25-10	40	30	VKFERC25I10	VKFERC25IL10
DN 25-16	40	30	VKFERC25I16	VKFERC25IL16
DN 40-16	55	30	VKFERC40I16	VKFERC40IL16
DN 40-25	55	40	VKFERC40I25	VKFERC40IL25
DN 50-25	75	40	VKFERC50I25	VKFERC50IL25
DN 50-40	75	55	VKFERC50I40	VKFERC50IL40

Embout cranté

VKFECR

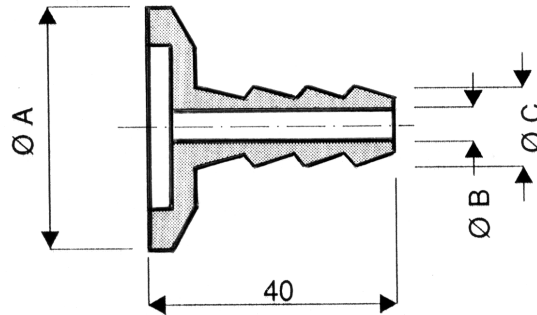

Ø nominal	A	B	C	Inox 316L
DN 10	30	9	13	VKFECR10IL14
DN 16	30	9	13	VKFECR16IL14
DN 25	40	9	12	VKFECR25IL12
DN 25	40	9	13	VKFECR25IL14
DN 25	40	16	20.50	VKFECR25IL21
DN 25	40	16	21.3	VKFECR25IL22
DN 40	55	9	13	VKFECR40IL14
DN 40	55	13	17.2	VKFECR40IL17
DN 40	55	16	20.50	VKFECR40IL21

Autres cotes sur demande

Embout fileté

VKFEFI

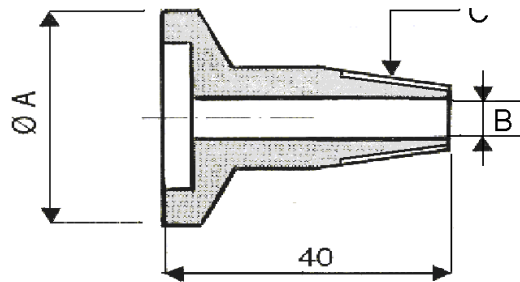

Ø nominal	A	B	C	Inox 316L GAZ	Inox 316L GAZ cyl.	Inox 316L NPT
DN 16	30	8	1/4"	VKFEFI16IL8G	VKFEFI16IL8GC	VKFEFI16IL8N
DN 16	30	12	3/8"	VKFEFI16IL12G	VKFEFI16IL12GC	VKFEFI16IL12N
DN16	30	15	1/2"	VKFEFI16IL15G	VKFEFI16IL15GC	VKFEFI16IL15N
DN 25	40	12	3/8"	VKFEFI25IL12G	VKFEFI25IL12GC	VKFEFI25IL12N
DN 25	40	15	1/2"	VKFEFI25IL15G	VKFEFI25IL15GC	VKFEFI25IL15N
DN 25	40	20	3/4"	VKFEFI25IL20G	VKFEFI25IL20GC	VKFEFI25IL20N
DN 25	40	25	1"	VKFEFI25IL25G	VKFEFI25IL25GC	VKFEFI25IL25N
DN 40	55	25	1"	VKFEFI40IL25G	VKFEFI40IL25GC	VKFEFI40IL25N
DN 40	55	30	1"1/4	VKFEFI40IL32G	VKFEFI40IL32GC	VKFEFI40IL32N
DN 40	55	40	1"1/2	VKFEFI40IL40G	VKFEFI40IL40GC	VKFEFI40IL40N
DN 50	75	40	1"1/2	VKFEFI50IL40G	VKFEFI50IL40GC	VKFEFI50IL40N
DN 50	75	50	2"	VKFEFI50IL50G	VKFEFI50IL50GC	VKFEFI50IL50N

Autre cotes sur demande

Embout taraudé VKFETA

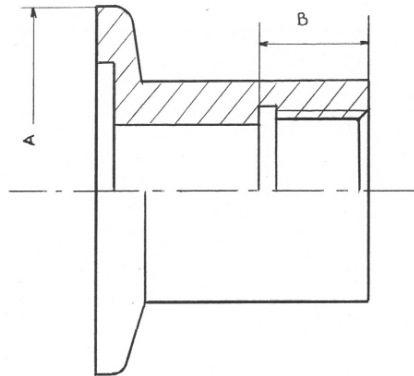

Ø nominal	A	B	C	Inox 316L GAZ cyl.	Inox 316L NPT
DN 16	30	10	1/4"	VKFETA16IL8GC	VKFETA16IL8N
DN 16	30	18	1/2"	VKFETA16IL15GC	VKFETA16IL15N
DN 25	40	10	1/4"	VKFETA25IL8GC	VKFETA25IL8N
DN 25	40	18	1/2"	VKFETA25IL15GC	VKFETA25IL15N

Autres cotes sur demande

Embout coudé VKFC

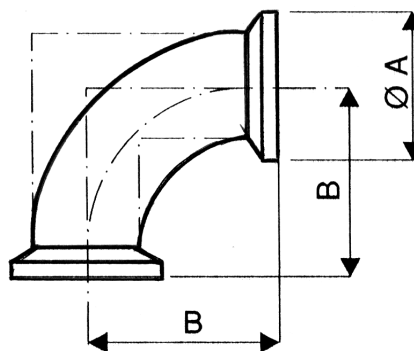

Ø nominal	A	B	Inox 316L	Inox 304
DN 16	30	Peut varier	VKFCE16IL	VKFCE16I
DN 25	40		VKFCE25IL	VKFCE25I
DN 40	55		VKFCE40IL	VKFCE40I
DN 50	75		VKFCE50IL	VKFCE50I

Autres DN sur demande

Embout en té réduit

VKFTR

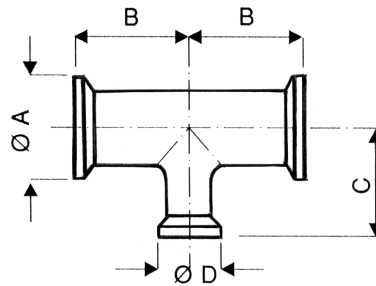

Ø nominal	A	B	C	D	Inox 316L	Inox 304
DN 25-10	40	Les dimensions B et C peuvent varier selon les nuances de matière		30	VKFTR25IL10	VKFTR25I10
DN 25-16	40			30	VKFTR25IL16	VKFTR25I16
DN 40-16	55			30	VKFTR40IL16	VKFTR40I16
DN 40-25	55			40	VKFTR40IL25	VKFTR40I25
DN 50-25	75			40	VKFTR50IL25	VKFTR50I25
DN 50-40	75			55	VKFTR50IL40	VKFTR50I40

Embout en té égal

VKFTE

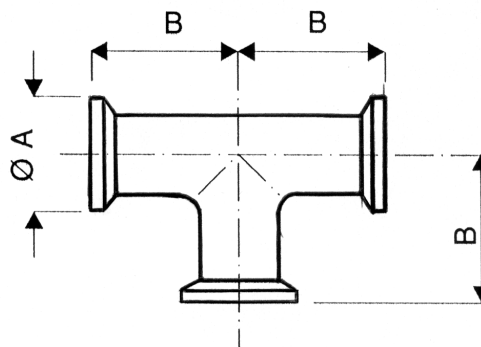

Ø nominal	A	B	Inox 316L	Inox 304
DN 16	30	Peut varier selon la nuance de matière	VKFTE16IL	VKFTE16I
DN 25	40		VKFTE25IL	VKFTE25I
DN 40	55		VKF40IL	VKFTE40I
DN 50	75		VKF50IL	VKFTE50I

Autres DN sur demande

Embout en croix égal VKFCR

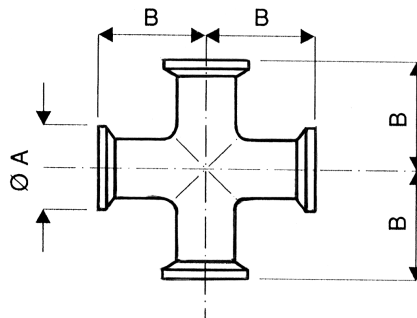

Ø nominal	A	B	Inox 316L	Inox 304
DN 16	30	Peut varier	VKFCR16IL	VKFCR16I
DN 25	40		VKFCR25IL	VKFCR25I
DN 40	55		VKFCR40IL	VKFCR40I
DN 50	75		VKFCR50IL	VKFCR50I

Autres DN sur demande

Embout en croix inégal VKFCRI

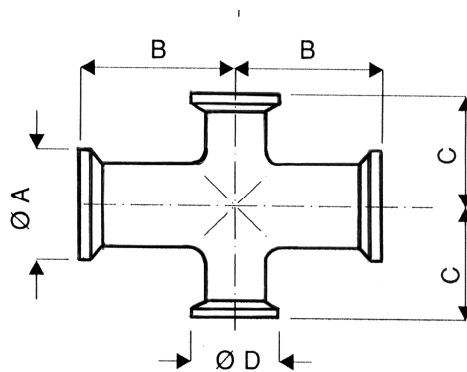

Ø nominal	A	B	C	D	Inox 316L
DN 25-16	40	Les cotes B et C peuvent varier		30	VKFCRI25IL16
DN 40-25	55			40	VKFCRI40IL25
DN 50-25	75			40	VKFCRI50IL25
DN 50-40	75			55	VKFCRI50IL40

Autres DN sur demande

Raccord souple

VKFFL

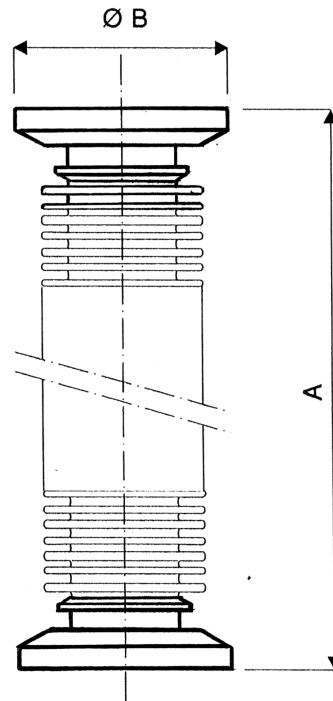

Matériau	Ø nominal	A	B	Référence
Inox	DN 16	120	30	VKFFL16I120
		250	30	VKFFL16I250
		500	30	VKFFL16I500
		750	30	VKFFL16I750
		1000	30	VKFFL25I1000
	DN 25	120	40	VKFFL25I120
		250	40	VKFFL25I250
		500	40	VKFFL25I500
		750	40	VKFFL25I750
		1000	40	VKFFL25I1000
	DN 40	120	55	VKFFL40I120
		250	55	VKFFL40I250
		500	55	VKFFL40I500
		750	55	VKFFL40I750
		1000	55	VKFFL40I1000
	DN 50	120	75	VKFFL50I120
		250	75	VKFFL50I250
		500	75	VKFFL50I500
		750	75	VKFFL50I750
		1000	75	VKFFL50I1000

Autres longueurs sur demande

Soufflet inox

VKFSO

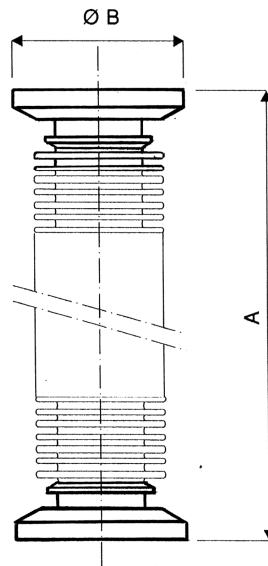

Ø nominal	A	B	Longueur compressée	Inox 304
DN 16	100	30	80	VKFSO16I100
DN 25	100	40	80	VKFSO25I100
DN 40	100	55	80	VKFSO40I100
DN 50	100	75	80	VKFSO50I100

Autres longueurs sur demande